

Vue éclatée structure / Exploded view - Structure

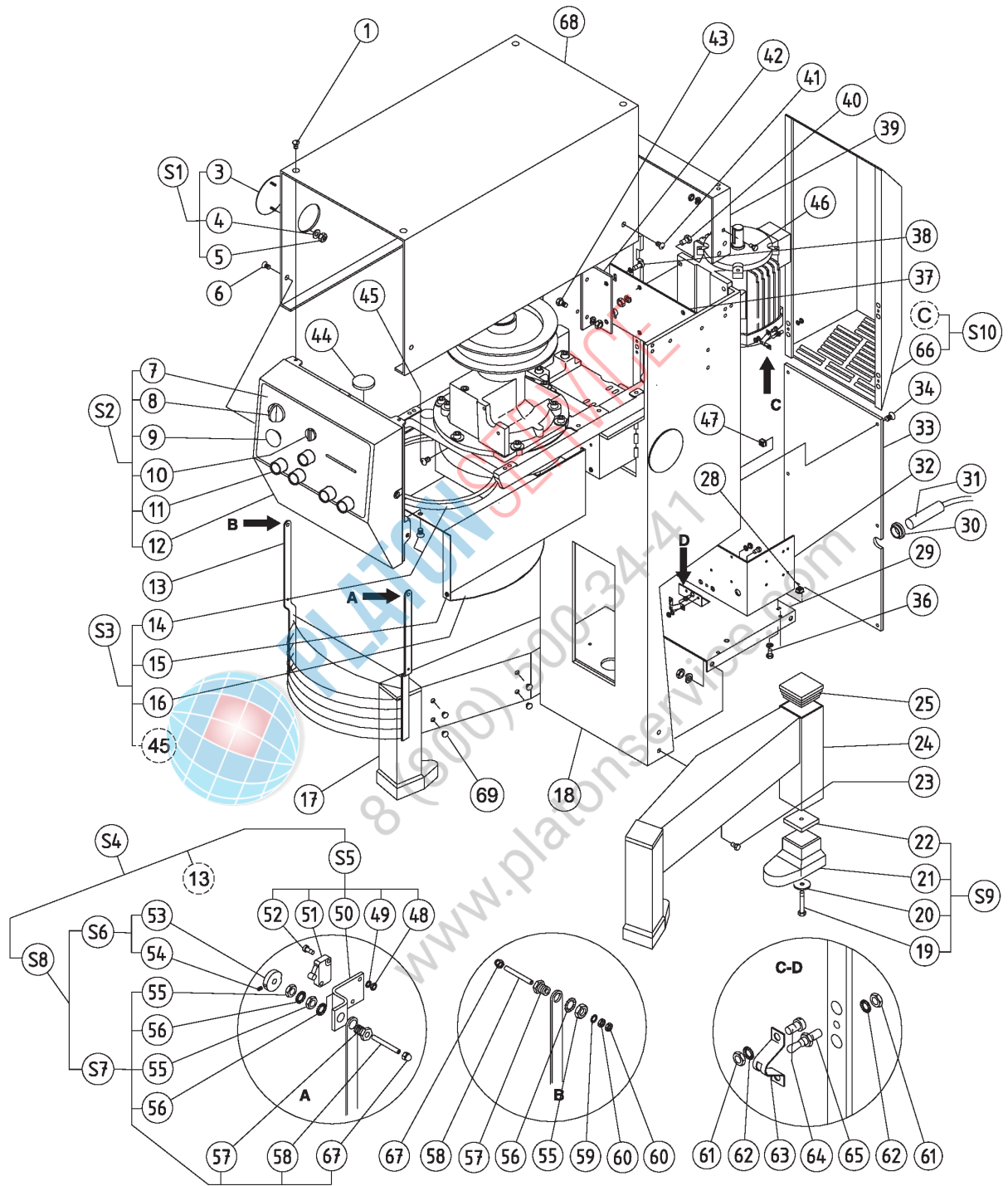

?????? 601188

?????? SPBMX(E)60-80 ???????? 2 Exploded view - Structure

.		Alias		S		.		(Euro)
0001	0D0517				D		VIS RL M8X16 INOX; 10 PCS	26,19
0003	000000						See S1	
0004	0D0631					+	WASHER; SET 10PCS	5,38
0005	OKL159						NUT; 10 PCS	18,37
0006	0D0517				D		VIS RL M8X16 INOX; 10 PCS	26,19
0007	0D3286				D		CONTROL PANEL BMX60	139,10
0007	0D5659				D		CONTROL PANEL; BMXE60	251,70
0007	0D5660				D		CONTROL PANEL; BMXE80	202,00
0007	0D5771				D		CONTROL PANEL; EM60	105,60
0007	0D5772				D		CONTROL PANEL; EM80	151,20
0008	OKQ287			S	A		TIMER W.KNOB	74,91
0009	OKQ687			S	A		STOP PUSH BUTTON	32,68
0010	OKQ648				A		KNOB EMX 60	22,43
0011	OKJ038			S	A		START BUTTON	20,40
0012	000000						See S2	
0013	0D5216		0D7799				PROTECTION SCREEN; BMX60	110,60
0014	0U0657						RUBBER STRIP	23,75
0015	0D2706				D		SELF-ADHESIVE RUBBER STOP SET X10	23,55
0016	000000						See S3	
0017	0D2748				D		LEFT FOOT ASSY STLESS STL BMX60	740,00
0017	0D3888		0D7797		D		BEIGE LEFT FOOT ASSY BMX60/80	551,00
0018	0D5663				D		COLUMN; BEIGE EQ BMX60	1 641,00
0018	0D5664				D		COLUMN; INOX EQ BMX60	2 395,00
0019	0D0598				D		SCREW; 10 PCS	21,62
0020	0D3581						FOOT WASHER MV50 (SET X10)	32,07
0021	000000						See S9	
0022	0D1956						NUT BM30	9,34
0023	0D2265						WASHER W10 BM40 SET X10	18,57
0023	0D2958				D		NUT HU M10 GALVA STL (SET X10)	21,42
0023	0D3554				D		SCREW H M10X25 AC 80 KG SET X10	20,40
0024	0D1546				D		RH LEG ASSEMBLY	523,00
0024	0D2747				D		RIGHT FOOT ASSY STLESS STL BMX60	740,00
0025	OKQ432						PLASTIC PLUG; 10 PCS	49,94
0028	0D1021				D		NUT; 10 PCS	23,14
0029	0D5666				D		PLAQUE; BMX60	61,61
0030	0D6160				D		PASSEFIL DA 9X16X4 JEU X5	25,68

?????? 601188

?????? SPBMX(E)60-80 ???????? 2 Exploded view - Structure

.		Alias		S		.		(Euro)
0031	0D1168				D		3/PHASE SUPPLY CABLE BM60	36,34
0032	0D5667				D		BRACKET; BMX60	117,70
0033	0D3442				D		LOWER REAR PLATE STLESS STL BNX6	162,40
0033	0D5668				D		TOLE ARRIERE; INF BEIGE BMX60	132,00
0034	0D0601						SCREW; 10 PCS	22,43
0036	0D0631					+	WASHER; SET 10PCS	5,38
0036	0D5298				D		SCREW; TH M4*12; T10-T15E; 10 PCS	19,54
0037	0D5670				D		PLAQUE; BMX60	51,36
0038	0KQ492						SCREW	21,01
0039	0D3889				D		OMEGA UPPER COLUMN BMX60	41,21
0040	0D2265						WASHER W10 BM40 SET X10	18,57
0040	0D2844						SCREW H M10X30 GALVA STL (SET X10)	21,21
0040	0D2958				D		NUT HU M10 GALVA STL (SET X10)	21,42
0041	0D0512						SCREW; 10 PCS	27,20
0042	0D5671				D		BRACKET; BMX60	31,36
0043	0D5641						SCREW; CHC M10X30 ACZN (JEU X10)	24,46
0044	0U0388						WINDOW	37,95
0045	0D2901						SCREW H BASE 6X16 STLESS STL SET X10	26,39
0046	0D2265						WASHER W10 BM40 SET X10	18,57
0046	0D2958				D		NUT HU M10 GALVA STL (SET X10)	21,42
0046	0D6064		S		D		VIS H M10X25 INOX (JEU X10)	25,78
0047	0D5647				D		NUT; CAGE M6X3,6-4,5 (JX10)	29,13
0048	033987					+	SCREW; 10 PCS	18,27
0049	0D2877						WASHER GALVA STL3 SET X10	17,92
0050	0D5672				D		BRACKET	12,14
0051	0D6661						MICROSWITCH; ECRAN BMX60/80	30,75
0052	0KQ511						SCREW; 10 PCS	18,37
0053	0U0391						CAM	17,32
0054	0KQ526						SCREW	19,64
0055	0KQ554				D		NUT; 10 PCS	21,01
0056	0KQ490				D		WASHER; 10 PCS	19,74
0057	0KQ333						SLEEVE	15,42
0058	0D6761				D		SCREW; SHC M8X70 INOX (JEU X10)	60,80
0059	0KQ523						NUT; 10 PCS	18,90
0060	0KQ524						WASHER; 10 PCS BMX60	20,27
0061	0D0579						NUT; 10 PCS	18,48

?????? 601188

?????? SPBMX(E)60-80 ???????? 2 Exploded view - Structure

.		Alias		S		.		(Euro)
0062	0KQ491						WASHER; 10 PCS	18,90
0063	0D5654			D			ATTACHE RAPID; (JEU X 5)	24,46
0064	0D0614			D			SCREW TC 5X12	19,54
0065	0D5444						DOWEL PIN; BMX60 (JEU X5)	31,77
0066	000000						See S10	
0067	0KL161						CAP NUT ; 10 PCS /M8	27,91
0068	0D6476			D			LID; M13 EQ BMX60/XBE60	323,80
0068	0D6477			D			LID; INOX EQ BMX/XBE	400,90
0069	0D3601						PLUG GPN 300 F9 DIAM.60MM	1,02
00S1	0D5655			D			COVER PLATE; EQ BMX60/80	64,45
00S2	0D0120			D			EQUIP. FRONT PANEL BMX60	652,00
00S2	0D1857			D			FRONT PANEL ASSY BMXE60	755,00
00S2	0D3287			D			FRONT PANEL ASSY BMXE80	771,00
00S2	0KV687			D			FRONT PANEL ASSEMBLY	563,00
00S3	0D6020			D			PROTECTION LATÉRALE EQ BMX60	614,00
00S4	0D0195			D			BMX60/S WIRE SAFETY GUARD PC60	270,00
00S5	0D1613						MICROSWITCH	48,52
00S6	0D5656			D			CAM; EQ BMX60/80	52,98
00S7	0D5657			D			BUSH; ARTICULATION EQ BMX60/80	41,82
00S8	0D1614						CAM	71,46
00S9	0KQ430						RUBBER FOOT	44,15
0S10	0D6478			D			HOOD; ARRIERE SUP RAL1013 BMX6	289,30
0S10	0D6479			D			HOOD; ARRIERE SUP INOX EQ BMX6	474,00

Vue éclatée variation vitesse mécanique/ Exploded view mechanical speed control

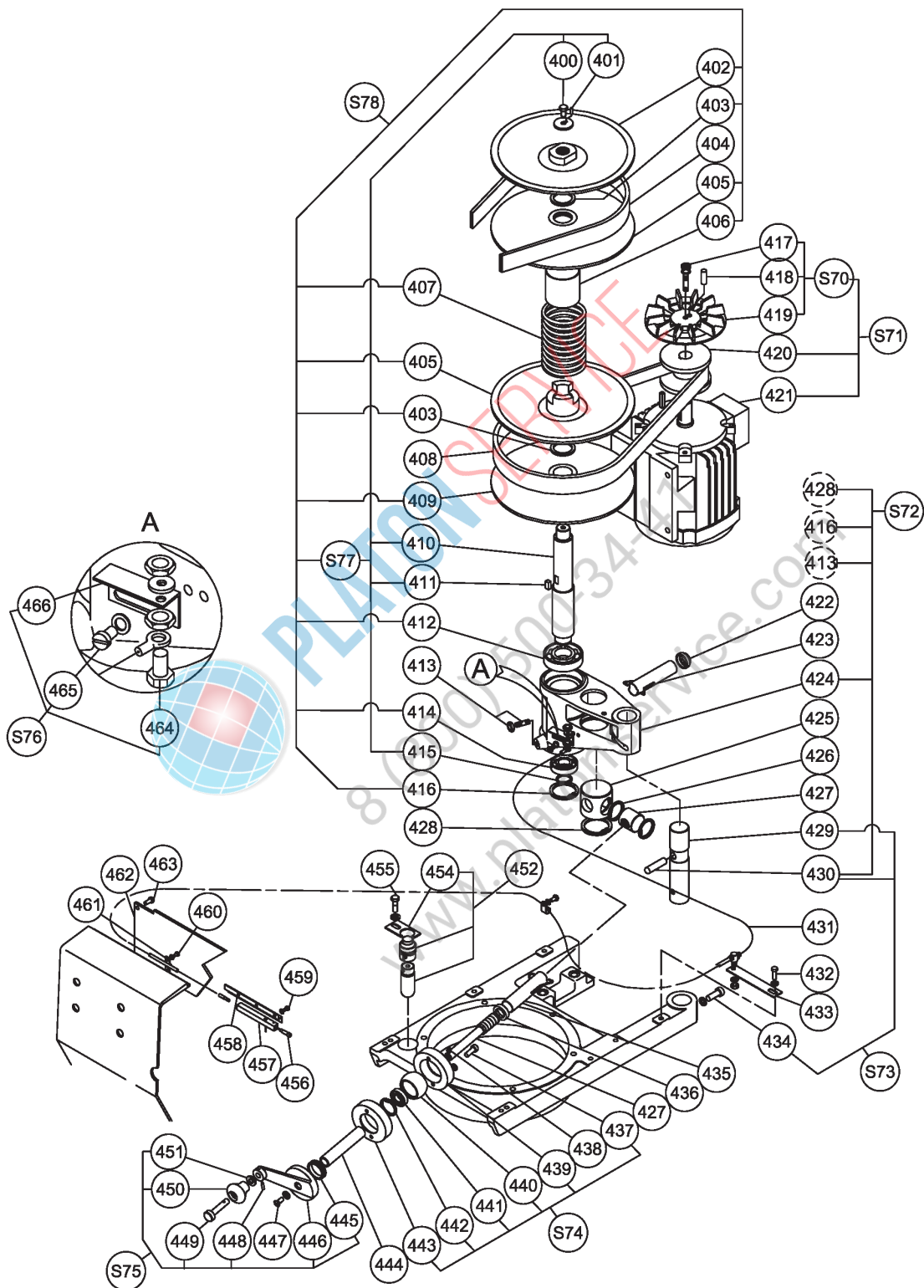

L

BMX60/80 FR 10 2010

??????		601188									
??????		SPBMX(E)60-80		???????? 12		Exploded view mechanical speed control					
.		Alias		S			.			(Euro)	
0400	0D0507								SCREW; 10 PCS	23,14	
0400	0D2323				D				FLANGE WASHER SET X10 BP45	124,80	
0401	0D3422								PIN GO5 4X10 STLESS STL SET X10	24,87	
0402	0D1310								BM60 FIXED UPPER FLANGE	136,00	
0403	0KQ576								GASKET; 5 PCS	23,45	
0404	0H1012			S	A				DRIVING BELT; W40X13X1365	101,50	
0405	0U0381								PULLEY FLANGE	197,90	
0406	0U0382								SLEEVE	27,30	
0407	0D3848								SPRING BM80	54,91	
0407	0KQ343								SPRING	23,75	
0408	0KJ740			S	A				DRIVING BELT; W40X13X875	78,87	
0409	0D1311								BM60 FIXED LOWER FLANGE	141,10	
0410	000000								See S77		
0411	0D5728				D				SPANNER; 10X8X20 H9 (JX10)	26,59	
0412	0D1124								BM60 BEARING 6207 2RS	11,41	
0413	0D0642								NUT; 10 PCS	19,85	
0413	0D1663				D				SCREW; 10 PCS	21,62	
0414	0D0006			S					BEARING	9,98	
0415	0D0654								B40/BM40/BM60/BE21 CIRCLIP 30E	21,42	
0416	0U0717								CLIP CD25 PEELER; 10 PCS	27,91	
0417	0D1663				D				SCREW; 10 PCS	21,62	
0417	0D3538				D				WASHER CS L8 GALVA STL8B (SET X10)	20,40	
0418	0KJ021								PIN; 5 PCS	24,97	
0419	000000								See S70		
0420	0D1312				D				BM60 DRIVE PULLEY	249,70	
0420	0D5342								DRIVING PULLEY; DEAN EQ BMX60		
0421	000000								See S71		
0421	0D1599								MOTOR; 440V 3PH 3,7A 2KW	315,70	
0421	0KQ289								MOTOR	316,70	
0422	0D0529								PROTECTIVE COVER; 10 PCS	30,86	
0423	0U0401				D				SCREW GUIDE	39,48	
0424	000000								See S72		
0425	0D0322								UNIVERSAL JOINT BMX80	65,67	
0426	0U0618								CIRCLIP 35I	21,62	
0427	0D1834				D				MANUAL CONTROL SCREW NUT BMX60	104,50	
0428	0D0578								CLIP; 10 PCS	29,13	

??????		601188									
??????		SPBMX(E)60-80		???????? 12		Exploded view mechanical speed control					
.		Alias		S			.			(Euro)	
0429	000000								See S73		
0430	0D0666							PIN G05 12X40 EM60; 5 PCS		32,99	
0431	0D0121							BMX60/80 SPEEDOMETER CABLE		82,62	
0432	0D0632							WASHER CS M8 (SET OF 10 PCS)		20,27	
0432	0D1709							SCREW; 10 PCS		22,43	
0433	0D5731				D			PATTE SUPPORT GAINE; BM60		12,14	
0434	0D2265							WASHER W10 BM40 SET X10		18,57	
0434	0D5641							SCREW; CHC M10X30 ACZN (JEU X10)		24,46	
0435	0D5733				D			FORREAU PROTECTION; AV BM60		36,03	
0436	0KQ307							SLEEVE BUSH		10,14	
0437	0D0599							SCREW; 10 PCS		21,92	
0437	0D0619							WASHER; 10 PCS		19,11	
0438	0D0552							SPANNER; 4X4X16; SET 5PCS		19,33	
0439	000000							See S74			
0440	000000							See S74			
0441	0D2393							BEARING 3202B-2RS		22,33	
0442	0U0618							CIRCLIP 35I		21,62	
0443	000000							See S74			
0444	0D3890							ENTRETOISE 15,8X21,3X111 BMX60		26,59	
0445	0D1134							V-RING 30X4X7,5		2,74	
0446	000000							See S75			
0447	0D0020							WASHER		4,85	
0447	0D0664							SCREW; 10 PCS		20,27	
0448	0D0671				D			PIN; 10 PCS		22,43	
0449	000000							See S75			
0450	000000							See S75			
0451	0D1219							WASHER 10X20X1		1,02	
0452	0KQ375				A			FLUORESCENT LAMP; 220V 40W; 26X80; NEW		75,01	
0454	0D1557				D			EQUERRE DOUILLE BMX60		18,80	
0455	0D0507							SCREW; 10 PCS		23,14	
0455	0D0626							WASHER; 10 PCS		18,90	
0456	0KQ447				A			PILOT LAMP; 220V		7,61	
0457	0KL039							BRACKET		47,40	
0458	0KQ624				D			GLIDE RAIL		27,10	
0459	0D0609							SCREW; 10 PCS		18,48	
0459	0D0621				D			WASHER; 10 PCS		18,90	

?????? 601188

?????? SPBMX(E)60-80 ???????? 12 Exploded view mechanical speed control

.		Alias		S		.		(Euro)
0460	0D0610						K35 SCREW TC 4X8	18,58
0460	0D0631					+	WASHER; SET 10PCS	5,38
0461	0D5735					D	PATTE BLOCAGE CABLE BM60 (JX5)	77,55
0462	0D5736						TOLE PROTECTION; BMX60	34,92
0463	0D5276						SCREW; TC M6*10 T10-15E; 10 PCS	20,27
0464	0D0579						NUT; 10 PCS	18,48
0464	0D5737					D	NUT; HM M5 INOX (JEU X10)	19,54
0464	0KQ407						SCREW; 10 PCS	19,43
0464	0KQ491						WASHER; 10 PCS	18,90
0465	0D0549						SCREW; 10 PCS	21,01
0465	0D0619						WASHER; 10 PCS	19,11
0466	000000						See S76	
0S70	0D5730					D	FAN; EQ BMX60/80	
0S70	0U0384					D	FAN BLADE; MODEL EM60/80 MIXER	94,80
0S71	0D2509					D	MOTOR 1 208/240 60 ASSY EM60/80	
0S71	0D2510					D	MOTOR 3 208/240 60 ASSY EM60/80	
0S72	0D0193						HINGE	426,30
0S73	0U0244					D	HINGE PIN	91,86
0S74	0U0257						BEARING	198,90
0S75	0KJ746						KNOB COMPL	210,10
0S76	0D0198					D	BM60 EQUIP. CABLE STOP	37,05
0S77	0D0182						BM60 VARIABLE PULLEY SHAFT	210,10
0S78	0D0065						BMX60 SHAFT+VARIABLE PULLEYS	1 027,00

Vue éclatée monte et baisse bol / Exploded view - Raising and lowering of bowl

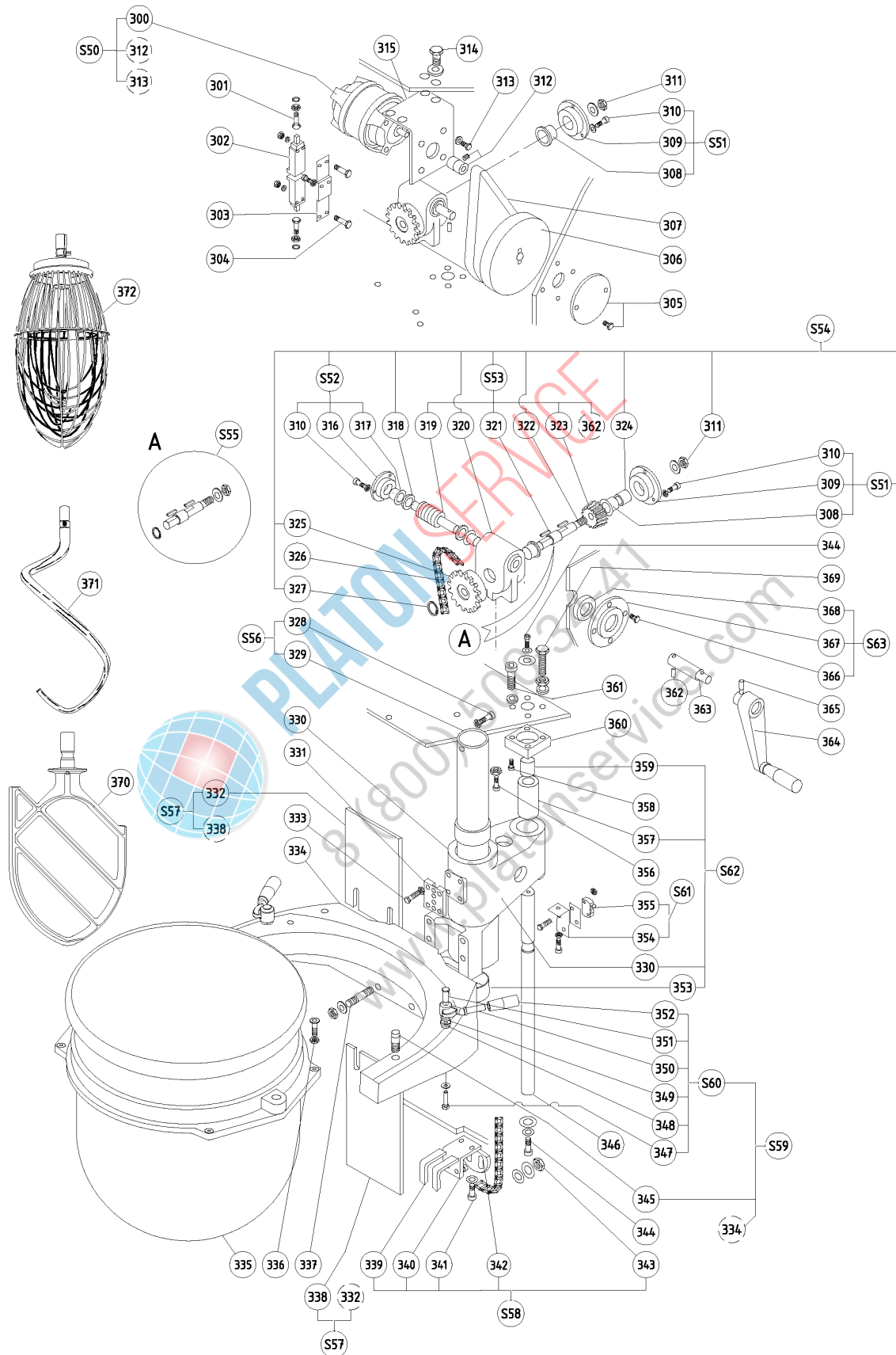

V

BMX60/80 FR 07 06

??????		601188									
??????		SPBMX(E)60-80		???????? 22		Exploded view - Raising and lowering of bowl					
.		Alias		S		.				(Euro)	
0300	000000									See S50	
0301	0D0598				D				SCREW; 10 PCS		21,62
0302	0KQ206				A				SWITCH		62,22
0303	0D3891				D				MICRO LIFT/LOWER SUPPORT BMX60		24,46
0304	0D0520								PIN; 10 PCS		18,90
0304	0D3399								SCREW CHC M4X40 STLESS STL SET X10		22,03
0304	0KL159								NUT; 10 PCS		18,37
0305	0D5309								OPERCULA; EQ BMX60		83,43
0306	0D1559								BMX60 RAISING LOWERING PULLEY		193,90
0307	033106			S	A				BELT; POLY V 559 J6		10,67
0308	0D5708				D				BEARING; COL 20X26X20 FP25 US		14,46
0309	000000									See S51	
0310	0D0617								SCREW CHC 6X15		20,27
0310	0D2876								WASHER W6 SET X10		17,37
0311	0D0622								WASHER; 10 PCS		19,11
0311	0D2958				D				NUT HU M10 GALVA STL (SET X10)		21,42
0312	0D0545								SCREW; 10 PCS		19,85
0312	0D1558								POULIE MOTRICE M/B BMX60		56,54
0313	0D0624						+		WASHER; SET 10PCS		3,97
0313	0KQ494								SCREW; 10 PCS		20,27
0314	0D2329								SCREW H M8X30 SET X10		23,24
0314	0D3538				D				WASHER CS L8 GALVA STL8B (SET X10)		20,40
0315	0D3892				D				SUPPORT MOTOR BMX60		66,58
0316	000000									See S52	
0317	0D6031				D				BALL BEARING; 15X51X20		66,18
0318	0D5710				D				WASHER; 30X15X2 (JX2)		33,09
0319	000000									See S53	
0320	0D5711				D				BOITIER REDUCTEUR; DEG BMX60		139,10
0321	0HD008								KEY; 5 PCS		21,32
0322	000000									See S55	
0323	000000									See S53	
0324	0D5712				D				SPACER; BM60		13,73
0325	0KQ341								CHAIN GEER WHEEL		124,80
0326	0KQ607								CHAIN + QUICK RELEASE		71,46
0327	0KQ557								RING; 10 PCS		19,54
0328	0D0499								SCREW; SET 10PCS; M6X16 INOX		20,06

??????		601188									
??????		SPBMX(E)60-80		???????? 22		Exploded view - Raising and lowering of bowl					
.		Alias		S		.				(Euro)	
0328	0D0503								NUT; 10 PCS		18,90
0329	000000								See S56		
0330	000000								See S61		
0331	0D5714				D				BRIDE CHAINE PEINT; BMX60		36,03
0332	000000								See S57		
0333	0D6084								VIS H EMB CRANTEE M8X30 (JX10)		22,74
0334	000000								See S59		
0335	653087								BOWL FOR 60LT MIXER		
0335	653132								BOWL FOR 80LT MIXER		
0336	0D0020								WASHER		4,85
0336	0D1031								SCREW; 10 PCS		19,54
0337	0D5700				D				WASHER; W 12 (JEU X5)		19,33
0337	0D5716				D				GOUJON; M12X68X25X25 ACDXZN JX6		47,71
0337	0KQ496								WASHER; 10 PCS		21,01
0338	000000								See S57		
0339	0D2702								SEAL STRIP 7X4 W:0.5 TBX130		21,01
0340	000000								See S58		
0341	0D2265								WASHER W10 BM40 SET X10		18,57
0341	0U0662								SCREW; 10 PCS		23,14
0342	0D5715				D				PATIN DE TENDEUR; BM60		31,16
0343	0D2958				D				NUT HU M10 GALVA STL (SET X10)		21,42
0343	0D3580				D				TOOTHED WASHER DD10 GALVA STL8B SET X10		22,74
0343	0KQ506								WASHER; 10 PCS		20,27
0344	0D0499								SCREW; SET 10PCS; M6X16 INOX		20,06
0344	0D3576								MILLED WASHER (SET X5)		34,61
0345	0D1030				D				LOCATING PIN; 2 PCS		40,80
0346	0D3637				D				LIFT LOWER ROD BM60		61,20
0347	0D0591								SCREW; 10 PCS		24,26
0347	0D3538				D				WASHER CS L8 GALVA STL8B (SET X10)		20,40
0348	0D5717				D				SPACER; (JX2)		25,58
0349	0D2662								O-RING 15.54X2.62 EL25 X5		20,91
0350	000000								See S60		
0351	0D6109				D				AXE VERROU XB40 (JEU X2)		30,35
0352	0D6125				D				POIGNEE I580/65 N-12		7,74
0353	0U0399				D				BUSH		17,32
0354	000000								See S61		

?????? 601188

?????? SPBMX(E)60-80 ???????? 22 Exploded view - Raising and lowering of bowl

.		Alias		S		.		(Euro)	
0354	0D0631						+	WASHER; SET 10PCS	5,38
0354	0D5298				D			SCREW; TH M4*12; T10-T15E; 10 PCS	19,54
0355	033986						+	SCREW; 10 PCS	18,06
0355	033987						+	SCREW; 10 PCS	18,27
0355	0D2877							WASHER GALVA STL3 SET X10	17,92
0355	0D6618							MICROSWITCH; MONTE/BAISSE 60L	29,54
0355	0KQ511							SCREW; 10 PCS	18,37
0355	0U0268							INSULATING PLATE	1,02
0356	0D2958				D			NUT HU M10 GALVA STL (SET X10)	21,42
0356	0D6064			S	D			VIS H M10X25 INOX (JEU X10)	25,78
0357	000000							See S62	
0358	0D5718				D			SCREW; FHC M10X20 AC 80 (JX10)	22,43
0359	0D5719				D			BEARING; 24X27X20 PA	5,60
0360	0D4743								
0361	0D2265							WASHER W10 BM40 SET X10	18,57
0361	0D5641							SCREW; CHC M10X30 ACZN (JEU X10)	24,46
0362	0D0396							PIN; 10 PCS	27,91
0363	0U0389				D			SHAFT FOR BOWL LIFT HANDLE	68,11
0364	0D3959							HANDLE; ASSY	79,17
0365	0D6180							GOUPILLE G01 5X30 (JEU X10)	31,26
0366	0D0664							SCREW; 10 PCS	20,27
0367	000000							See S63	
0368	0D3636				D			HANDLE RING BM60	21,92
0369	0D5722				D			SCREW; H M10X55 INOX (JEU X10)	35,53
0370	653083							PADDLE FOR 60LT MIXER	297,40
0370	653135							PADDLE FOR 80LT MIXER	456,60
0370	653457							PADDLE-MEAT PROCESSING- FOR 60LT MIXER	
0371	653084							DOUGH HOOK FOR 60LT MIXER	960,00
0371	653133							DOUGH HOOK FOR 80LT MIXER	1 025,00
0371	653481							HEAVY DUTY HOOK FOR 60LT PLANETARY MIXER	1 026,00
0372	653086							WHISK FOR 60LT MIXER	519,00
0372	653134							WHISK FOR 80LT MIXER	899,00
0372	653458							WHISK-MEAT PROCESSING - FOR 60LT MIXER	
0S50	0KQ668							AUXILIARY MOTOR	513,00
0S51	0D5723				D			THRUST BEARING; EQ BMX60	81,30
0S52	0D5709				D			THRUST BEARING; EQ BMX60	112,70

?????? 601188
 ?????? SPBMX(E)60-80 ???????? 22 Exploded view - Raising and lowering of bowl

.		Alias		S		.		(Euro)
0S53	0U0540						GEAR	225,30
0S54	0U0248						BOWL LIFT GEARBOX ASSY EMXE80	692,00
0S55	0U0247						REDUCTION SHAFT FOR BOWL LIFT	82,93
0S56	0D5310			D			TUBE; D60 EQ BM60	148,20
0S57	0D5811			D			TOLE PROTECTION INF/SUP BMX60	92,16
0S58	0U0249			D			TENSIONING BLOCK & BRACKET	90,84
0S59	0D5725							
0S59	0U0250			D			BOWL SUPPORT EM80	493,30
0S60	0D6117			S			LOCK BOLT; XBM40	63,34
0S61	0D5724						MICROSWITCH; M/B EQ BMX60	47,40
0S62	0D5713			D			SUPPORT; EQ BMX60	451,70
0S63	0D5721			D			THRUST BEARING; EQ BMX60	127,90



PLATON SERVICE
 8 (800) 500-34-47
 www.platonservice.com

Vue éclatée variateur / Exploded view - head with accessory socket

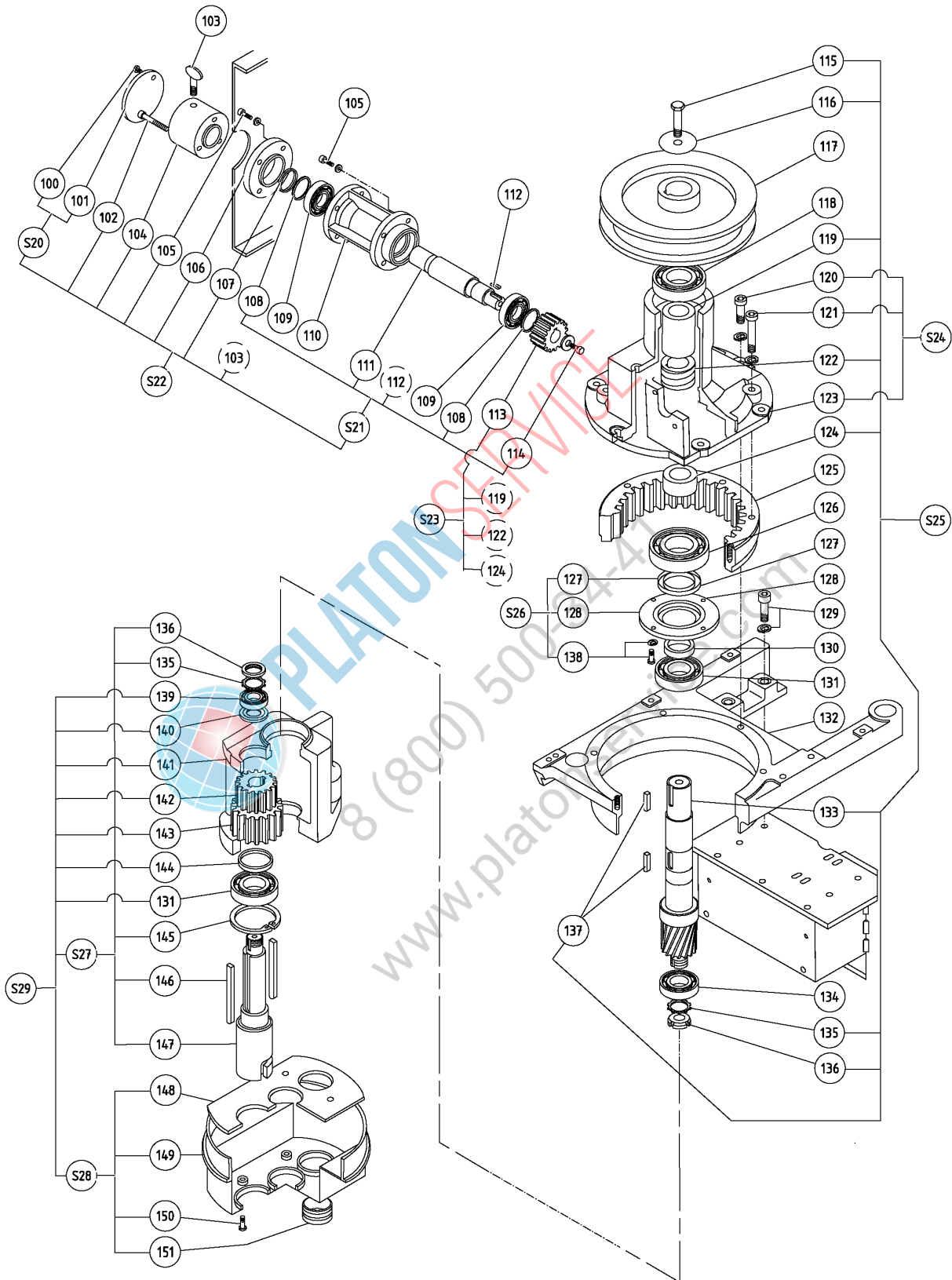

FF

BMX60/80 FR 06 06

??????		601188									
??????		SPBMX(E)60-80		???????? 32		Exploded view - head with accessory socket					
.		Alias		S			.			(Euro)	
0100	0D3547				D			SCREW F M4X12 STLESS STL (SET X10)		20,60	
0101	000000								See S20		
0102	0D1018							SCREW; 10 PCS		25,27	
0103	0KQ334							WING BOLT; M10X30		13,62	
0104	0KL098							SHEATH		99,47	
0105	0D0657				D			SCREW; 10 PCS		19,43	
0105	0D2876							WASHER W6 SET X10		17,37	
0106	0D5692				D			SPACER; PA BM60		75,11	
0107	0H1040							SEAL; 5 PCS		26,19	
0108	0D0654							B40/BM40/BM60/BE21 CIRCLIP 30E		21,42	
0109	0KT993							BEARING		8,42	
0110	0D5693				D			PORTE CANON; DEG BMX60		142,10	
0111	000000								See S21		
0112	0D0637							WEDGE; 5 PCS		19,95	
0113	0D1226				D			BM60 ATTACHMENT HUB WHEEL		151,20	
0114	0D3576							MILLED WASHER (SET X5)		34,61	
0114	0KQ520							SCREW; 10 PCS		20,27	
0115	0D3554				D			SCREW H M10X25 AC 80 KG SET X10		20,40	
0116	0D5695							WASHER; POULIE 60X10 (JEU X5)		59,07	
0117	0D5706				D			DRIVEN PULLEY; BMX60		230,40	
0118	0D1129							BM60 6308EE BEARING		18,06	
0119	0D5780							TOP SPACER; BMX60		44,32	
0120	0D2265							WASHER W10 BM40 SET X10		18,57	
0120	0D6099							VIS CHC M10X40 AC 80 (JEU X10)		21,52	
0121	0D2265							WASHER W10 BM40 SET X10		18,57	
0121	0D5696							SCREW; CHC M10X60 AC.80KG (J X10)		24,46	
0122	0D1726				D			SCREW		244,60	
0123	000000								See S24		
0124	0D5781							LOWER SPACER ; BMX60		50,40	
0125	0D3168							CROWN GEAR 53TEETH ASSY BMX60		224,30	
0126	0D1130							BEARING; 6309 2RS		23,45	
0127	0D1133							BM60 C 55 X 70 X 8 SEAL		5,60	
0128	000000								See S26		
0129	0D5699				D			SCREW; CHC M12X45 AC.80KG (J X5)		21,72	
0129	0D5700				D			WASHER; W 12 (JEU X5)		19,33	
0130	0U0374							SUN GEAR SHAFT SPACER		38,37	

??????		601188									
??????		SPBMX(E)60-80		???????? 32		Exploded view - head with accessory socket					
.		Alias		S			.			(Euro)	
0131	0HD044			S					BEARING; TR-300		12,82
0132	0D5701				D				PLATINE EMBALLEE; BMX60		557,00
0133	000000									See S25	
0134	0KJ748			S					BALL BEARING; 6305 2RS		10,85
0135	0D5042								WASHER; MB5		1,02
0136	0D0002								NUT		4,54
0137	0D0543				D				SPANNER; 12X8X36; SET 5PCS		27,51
0138	0D0499								SCREW; SET 10PCS; M6X16 INOX		20,06
0138	0D0624						+		WASHER; SET 10PCS		3,97
0139	0KQ394			S	A				BEARING; 6205 2RS		7,50
0140	0U0375								UPPER SPACER		18,58
0141	0D1216				D				PLANETARY HOUSING BMX60		217,20
0142	0U0373								SPEAR GEAR (17 TEETH) EMX60		86,68
0143	0U0372								HELICORE GEAR(24 TEETH) EMX60		119,80
0144	0U0376								LOWER SPACER (EMX80)		25,78
0145	0U0668								CLIP; 5 PCS		25,88
0146	0D2340								COTTERPIN A10X8X115 BM60 SET X2		28,42
0147	000000									See S27	
0148	0U0292								GASKET		6,76
0149	000000									See S28	
0150	0D0595								SCREW; 10 PCS		20,71
0151	0D1054								PLUG; 4 PCS		22,33
0S20	0KL100								COVER PLATE ASSEMBLY		44,56
0S21	0D2545								ACCSSRY SOCKT SHAFT ASSY BMX60		116,70
0S22	0D0958				D				BMX60/80 ATTACHMENT HUB ASSY		438,50
0S23	0U0540								GEAR		225,30
0S24	0D5703				D				THRUST BEARING; PA EQ BMX60		560,00
0S25	0D1409								BM60 SUN SHAFT ASSEMBLY		519,00
0S26	0U0698								BEARING COVER & SEAL		121,80
0S27	0U0243								BEATER SHAFT ASSY		266,90
0S28	0D5204								HOUSING; BM60		112,70
0S28	0D5704										
0S29	0D1858				D				PLANETARY SUPPORT ASSY BMX60/80		
0S29	0D5705								SUPPORT; STD EQ BMX6		823,00

Vue éclatée tête sans prise accessoires / Exploded view - head without accessory socket / Explosionszeichnung Kopf ohne Aufstecknabe

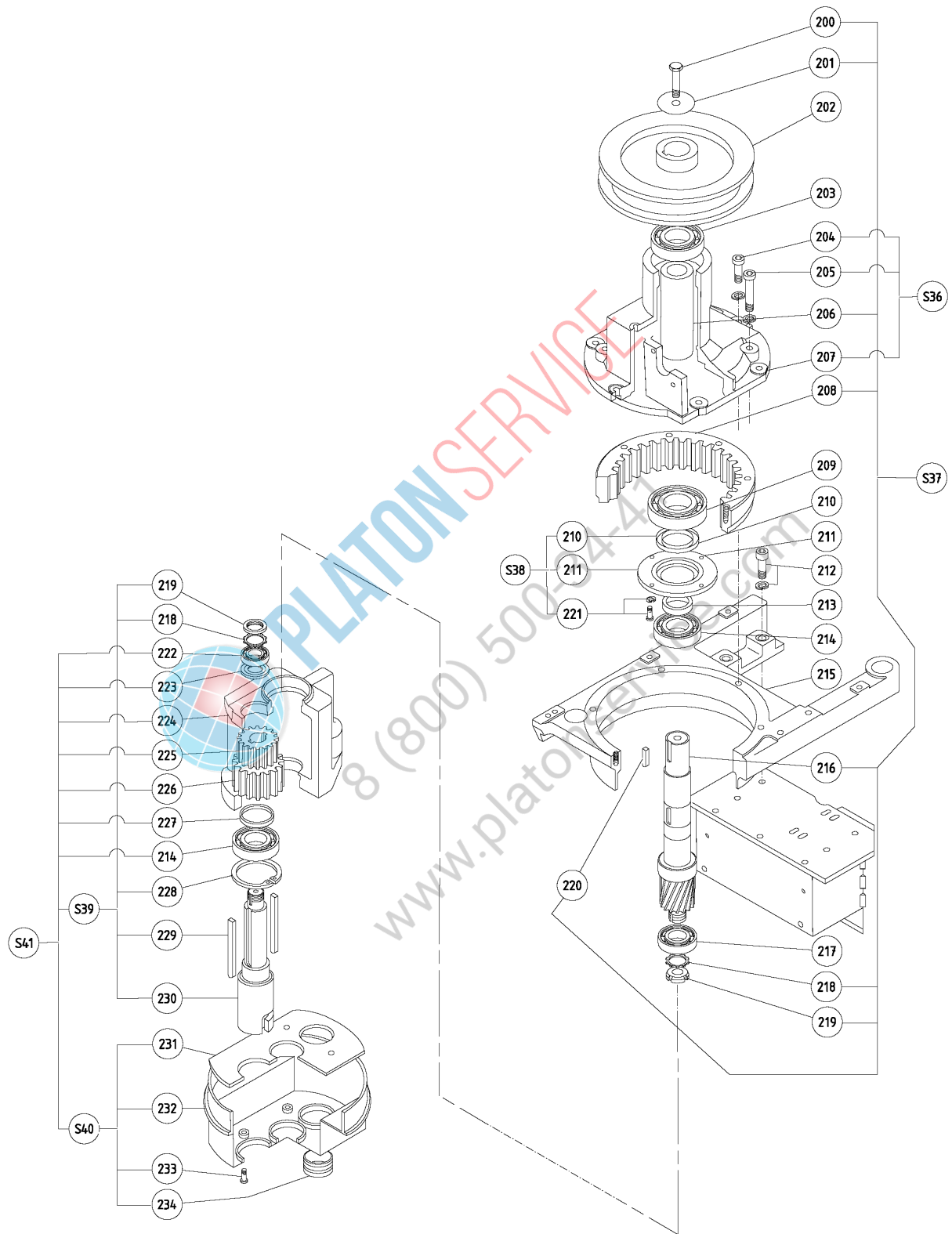

PP

BMX60/80 FR 06 06

?????? 601188

?????? SPBMX(E)60-80 ???????? 42 Exploded view - head without accessory socket

.		Alias		S		.		(Euro)
0200	0D3554				D		SCREW H M10X25 AC 80 KG SET X10	20,40
0201	0D5695						WASHER; POULIE 60X10 (JEU X5)	59,07
0202	0D5706				D		DRIVEN PULLEY; BMX60	230,40
0203	0D1129						BM60 6308EE BEARING	18,06
0204	0D2265						WASHER W10 BM40 SET X10	18,57
0204	0D6099						VIS CHC M10X40 AC 80 (JEU X10)	21,52
0205	0D2265						WASHER W10 BM40 SET X10	18,57
0205	0D5696						SCREW; CHC M10X60 AC.80KG (J X10)	24,46
0206	0D5732							
0207	000000							See S36
0208	0D3168						CROWN GEAR 53TEETH ASSY BMX60	224,30
0209	0D1130						BEARING; 6309 2RS	23,45
0210	0D1133						BM60 C 55 X 70 X 8 SEAL	5,60
0211	000000							See S38
0212	0D5699				D		SCREW; CHC M12X45 AC.80KG (J X5)	21,72
0212	0D5700				D		WASHER; W 12 (JEU X5)	19,33
0213	0U0374						SUN GEAR SHAFT SPACER	38,37
0214	0HD044			S			BEARING; TR-300	12,82
0215	0D5701				D		PLATINE EMBALLEE; BMX60	557,00
0216	000000							See S37
0217	0KJ748			S			BALL BEARING; 6305 2RS	10,85
0218	0D5042						WASHER; MB5	1,02
0219	0D0002						NUT	4,54
0220	0D0543				D		SPANNER; 12X8X36; SET 5PCS	27,51
0221	0D0499						SCREW; SET 10PCS; M6X16 INOX	20,06
0221	0D0624					+	WASHER; SET 10PCS	3,97
0222	0KQ394			S	A		BEARING; 6205 2RS	7,50
0223	0U0375						UPPER SPACER	18,58
0224	0D1216				D		PLANETARY HOUSING BMX60	217,20
0225	0U0373						SPEAR GEAR (17 TEETH) EMX60	86,68
0226	0U0372						HELICORE GEAR(24 TEETH) EMX60	119,80
0227	0U0376						LOWER SPACER (EMX80)	25,78
0228	0U0668						CLIP; 5 PCS	25,88
0229	0D2340						COTTERPIN A10X8X115 BM60 SET X2	28,42
0230	000000							See S39
0231	0U0292						GASKET	6,76

?????? 601188
 ?????? SPBMX(E)60-80 ???????? 42 Exploded view - head without accessory socket

.		Alias		S		.		(Euro)
0232	000000						See S40	
0233	0D0595					SCREW; 10 PCS		20,71
0234	0D1054					PLUG; 4 PCS		22,33
0S36	0D2713			D		REDUCER BEARING W/O ACCSSRY SOCKT ASSY B		521,00
0S37	0KL002					SUN SHAFT ASSEMBL; EMX60/80		347,10
0S38	0U0698					BEARING COVER & SEAL		121,80
0S39	0U0243					BEATER SHAFT ASSY		266,90
0S40	0D5204					HOUSING; BM60		112,70
0S40	0D5704							
0S41	0D1858			D		PLANETARY SUPPORT ASSY BMX60/80		
0S41	0D5705					SUPPORT; STD EQ BMX6		823,00



PLATON SERVICE
 8 (800) 500-34-41
 www.platonservice.com

Vue éclatée variation vitesse électrique / Exploded view electric speed control / Explosionszeichnungelektronische Geschwindigkeitsregelung

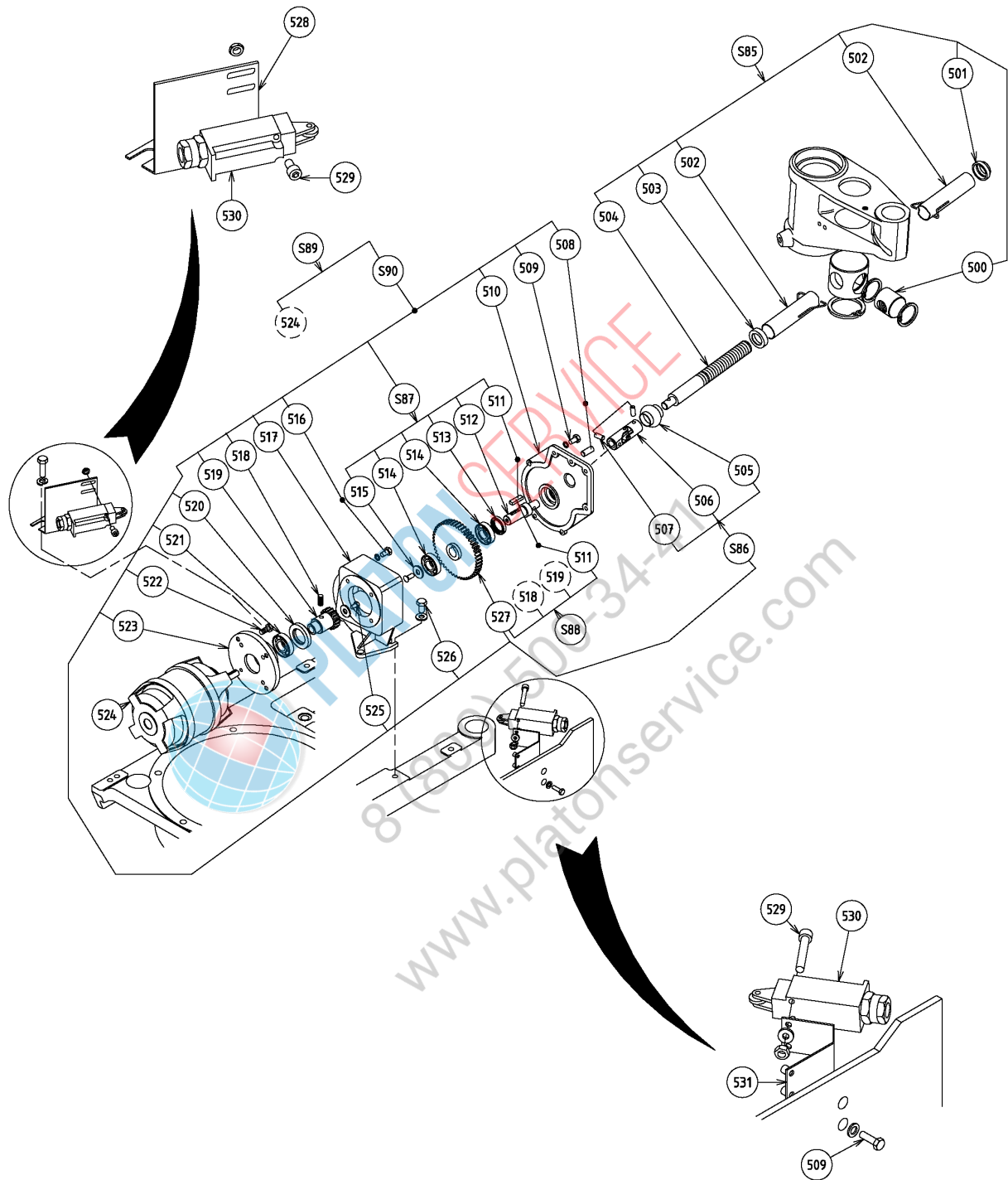

??????		601188									
??????		SPBMX(E)60-80		???????? 48		Exploded view - electric speed control					
.		Alias		S		.				(Euro)	
0500	0KQ539								NUT	73,59	
0501	0D0529								PROTECTIVE COVER; 10 PCS	30,86	
0502	0U0401				D				SCREW GUIDE	39,48	
0503	0KQ307								SLEEVE BUSH	10,14	
0504	0D5740								SCREW; USINNE BMX60/80	56,43	
0505	0G1694								HALTER	38,57	
0506	0G1693								GELENK	66,58	
0507	0U0663								PIN; 10 PCS	30,55	
0508	0KQ500								PIN 8X20; 10 PCS	25,68	
0509	0D0499								SCREW; SET 10PCS; M6X16 INOX	20,06	
0509	0D0624						+		WASHER; SET 10PCS	3,97	
0510	0D5753				D				LID; DEG BMX60	154,30	
0511	0D0646								B20 KEY REP 66B	21,32	
0512	000000								See S87		
0513	0KI591								SEALING	2,84	
0514	0U0582								BEARING	3,67	
0515	0D0020								WASHER	4,85	
0515	0KQ520								SCREW; 10 PCS	20,27	
0516	0KQ407								SCREW; 10 PCS	19,43	
0516	0KQ514								SEALING WASHER; SET 10PCS	21,62	
0517	0D3466				D				CASING ONLY SPEED REDUCER BMXE60		
0518	0D0545								SCREW; 10 PCS	19,85	
0519	000000								See S88		
0520	0KQ579								SEAL 24X40X7, INOUT SHAFT; 5 PCS	26,59	
0521	0U0282				D				BEARING	5,11	
0522	0D5276								SCREW; TC M6*10 T10-15E; 10 PCS	20,27	
0523	0D5741				D				ADAPTER; MOTEUR BM60	85,77	
0524	0D5742				D				MOT 3 220/380 60 CGHT V BMX60	448,60	
0524	0U0541								MOTOR ASSY COMPL.	485,20	
0525	0D0545								SCREW; 10 PCS	19,85	
0525	0D5743				D				WASHER; 4,5X14X2 (JEU X10)	23,75	
0526	0D0632								WASHER CS M8 (SET OF 10 PCS)	20,27	
0526	0D0642								NUT; 10 PCS	19,85	
0526	0D5444								DOWEL PIN; BMX60 (JEU X5)	31,77	
0527	000000								See S88		
0528	0D5744				D				BRACKET; BMX60	36,74	

??????	601188								
??????	SPBMX(E)60-80	???????? 48					Exploded view - electric speed control		
.		Alias		S			.		(Euro)
0529	0D0520							PIN; 10 PCS	18,90
0529	0D3399							SCREW CHC M4X40 STLESS STL SET X10	22,03
0529	0KL159							NUT; 10 PCS	18,37
0530	0KQ206				A			SWITCH	62,22
0531	0U0485				D			MINI MICRO SPEED BRACKET	39,18
0S85	0G1692				A			CONTROL SCREW KIT	214,20
0S86	0KQ667							PLANETARY GEAR ASSY.	128,90
0S87	0D2712				D			OUTPUT SHAFT ASSY BMXE60/80	218,20
0S88	0D3465							SPEED REDUCER PINION BMXE60/80 (SET)	252,70
0S89	0U0585							MOTOR	1 240,00
0S90	0D6613		0U0585		D			SPEED REDUCER; ELECT.BMXE60	



PLATON SERVICE
 8 (800) 500-34-41
 www.platonservice.com